

**Robert Bosch GmbH**  
Power Tools Division  
70745 Leinfelden-Echterdingen

[www.bosch-pt.com](http://www.bosch-pt.com)

1 609 929 M73 (2007.10) PS / 112

## GDS 24 Professional GDS 30 Professional

 **BOSCH**

**de** Originalbetriebsanleitung  
**en** Original instructions  
**fr** Notice originale  
**es** Manual original  
**pt** Manual original  
**it** Istruzioni originali  
**nl** Oorspronkelijke  
gebruiksaanwijzing

**da** Original brugsanvisning  
**sv** Bruksanvisning i original  
**no** Original driftsinstruks  
**fi** Alkuperäiset ohjeet  
**el** Πρωτότυπο οδηγιών χρήσης  
**tr** Orijinal işletme talimatı



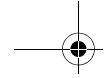

Deutsch . . . . .	Seite	4
English . . . . .	Page	12
Français . . . . .	Page	20
Español . . . . .	Página	28
Português . . . . .	Página	37
Italiano . . . . .	Pagina	45
Nederlands . . . . .	Pagina	53
Dansk . . . . .	Side	61
Svenska . . . . .	Sida	69
Norsk . . . . .	Side	77
Suomi . . . . .	Sivu	85
Ελληνικά . . . . .	Σελίδα	93
Türkçe . . . . .	Sayfa	102

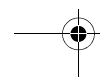
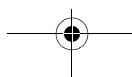
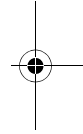
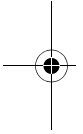

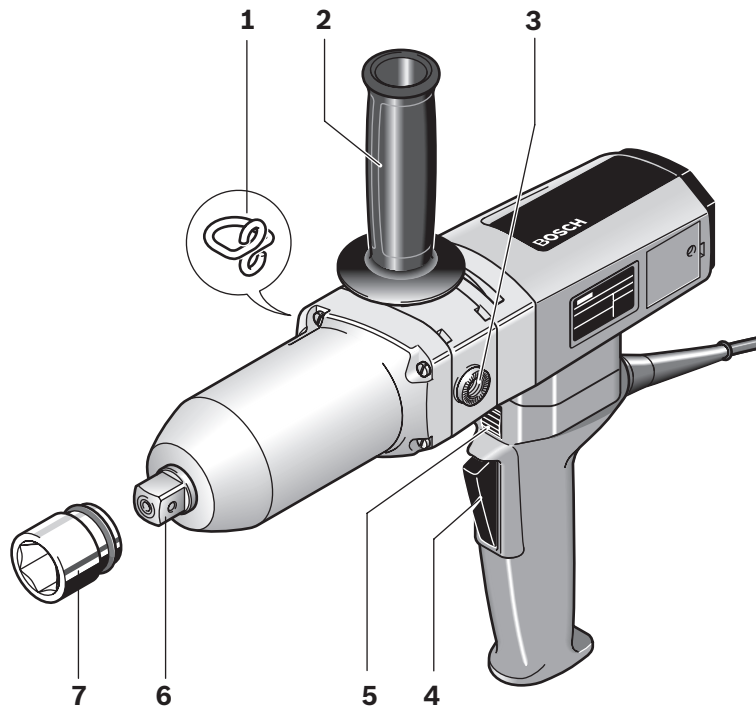

GDS 24 Professional  
GDS 30 Professional

## General Power Tool Safety Warnings

**⚠ WARNING** Read all safety warnings and all instructions. Failure to follow the warnings and instructions may result in electric shock, fire and/or serious injury.

**Save all warnings and instructions for future reference.**

The term "power tool" in the warnings refers to your mains-operated (corded) power tool or battery-operated (cordless) power tool.

### 1) Work area safety

- a) **Keep work area clean and well lit.** Cluttered or dark areas invite accidents.
- b) **Do not operate power tools in explosive atmospheres, such as in the presence of flammable liquids, gases or dust.** Power tools create sparks which may ignite the dust or fumes.
- c) **Keep children and bystanders away while operating a power tool.** Distractions can cause you to lose control.

### 2) Electrical safety

- a) **Power tool plugs must match the outlet. Never modify the plug in any way. Do not use any adapter plugs with earthed (grounded) power tools.** Unmodified plugs and matching outlets will reduce risk of electric shock.
- b) **Avoid body contact with earthed or grounded surfaces, such as pipes, radiators, ranges and refrigerators.** There is an increased risk of electric shock if your body is earthed or grounded.
- c) **Do not expose power tools to rain or wet conditions.** Water entering a power tool will increase the risk of electric shock.
- d) **Do not abuse the cord. Never use the cord for carrying, pulling or unplugging the power tool. Keep cord away from heat, oil, sharp edges and moving parts.** Damaged or entangled cords increase the risk of electric shock.

e) **When operating a power tool outdoors, use an extension cord suitable for outdoor use.** Use of a cord suitable for outdoor use reduces the risk of electric shock.

f) **If operating a power tool in a damp location is unavoidable, use a residual current device (RCD) protected supply.** Use of an RCD reduces the risk of electric shock.

### 3) Personal safety

- a) **Stay alert, watch what you are doing and use common sense when operating a power tool. Do not use a power tool while you are tired or under the influence of drugs, alcohol or medication.** A moment of inattention while operating power tools may result in serious personal injury.
- b) **Use personal protective equipment. Always wear eye protection.** Protective equipment such as dust mask, non-skid safety shoes, hard hat, or hearing protection used for appropriate conditions will reduce personal injuries.
- c) **Prevent unintentional starting. Ensure the switch is in the off-position before connecting to power source and/or battery pack, picking up or carrying the tool.** Carrying power tools with your finger on the switch or energising power tools that have the switch on invites accidents.
- d) **Remove any adjusting key or wrench before turning the power tool on.** A wrench or a key left attached to a rotating part of the power tool may result in personal injury.
- e) **Do not overreach. Keep proper footing and balance at all times.** This enables better control of the power tool in unexpected situations.
- f) **Dress properly. Do not wear loose clothing or jewellery. Keep your hair, clothing and gloves away from moving parts.** Loose clothes, jewellery or long hair can be caught in moving parts.

- g) If devices are provided for the connection of dust extraction and collection facilities, ensure these are connected and properly used.** Use of dust collection can reduce dust-related hazards.
- 4) Power tool use and care**
- a) Do not force the power tool. Use the correct power tool for your application.** The correct power tool will do the job better and safer at the rate for which it was designed.
- b) Do not use the power tool if the switch does not turn it on and off.** Any power tool that cannot be controlled with the switch is dangerous and must be repaired.
- c) Disconnect the plug from the power source and/or the battery pack from the power tool before making any adjustments, changing accessories, or storing power tools.** Such preventive safety measures reduce the risk of starting the power tool accidentally.
- d) Store idle power tools out of the reach of children and do not allow persons unfamiliar with the power tool or these instructions to operate the power tool.** Power tools are dangerous in the hands of untrained users.
- e) Maintain power tools. Check for misalignment or binding of moving parts, breakage of parts and any other condition that may affect the power tool's operation. If damaged, have the power tool repaired before use.** Many accidents are caused by poorly maintained power tools.
- f) Keep cutting tools sharp and clean.** Properly maintained cutting tools with sharp cutting edges are less likely to bind and are easier to control.
- g) Use the power tool, accessories and tool bits etc. in accordance with these instructions, taking into account the working conditions and the work to be performed.** Use of the power tool for operations different from those intended could result in a hazardous situation.
- 5) Service**
- a) Have your power tool serviced by a qualified repair person using only identical replacement parts.** This will ensure that the safety of the power tool is maintained.

## Machine-specific Safety Warnings

- ▶ **Never use the machine with a damaged cable. Do not touch the damaged cable and pull the mains plug when the cable is damaged while working.** Damaged cables increase the risk of an electric shock.
- ▶ **When working with the machine, always hold it firmly with both hands and provide for a secure stance.** The power tool is guided more secure with both hands.
- ▶ **Secure the workpiece.** A workpiece clamped with clamping devices or in a vice is held more secure than by hand.
- ▶ **Always wait until the machine has come to a complete stop before placing it down.** The tool insert can jam and lead to loss of control over the power tool.

## Functional Description



**Read all safety warnings and all instructions.** Failure to follow the warnings and instructions may result in electric shock, fire and/or serious injury.

While reading the operating instructions, unfold the graphics page for the machine and leave it open.

### Intended Use

The machine is intended for driving in and loosening screws and bolts as well as for tightening and loosening nuts within the respective range of dimension.

### Product Features

The numbering of the product features refers to the illustration of the machine on the graphics page.

- 1 Suspension hook
- 2 Auxiliary handle
- 3 Threaded for auxiliary handle
- 4 On/Off switch
- 5 Rotational direction switch
- 6 Tool holder
- 7 Tool bit

**The accessories illustrated or described are not included as standard delivery.**

## Noise/Vibration Information

Measured values determined according to EN 60745.

Typically the A-weighted noise levels of the product are: Sound pressure level 100 dB(A); Sound power level 113 dB(A). Uncertainty K=3 dB.

### Wear hearing protection!

Vibration total values (triax vector sum) determined according to EN 60745:

Impact tightening of fasteners of the maximum capacity of the tool: Vibration emission value  $a_h=4 \text{ m/s}^2$ , Uncertainty K=0.5  $\text{m/s}^2$ .

The vibration emission level given in this information sheet has been measured in accordance with a standardised test given in EN 60745 and may be used to compare one tool with another. It may be used for a preliminary assessment of exposure.

The declared vibration emission level represents the main applications of the tool. However if the tool is used for different applications, with different accessories or poorly maintained, the vibration emission may differ. This may significantly increase the exposure level over the total working period.

An estimation of the level of exposure to vibration should also take into account the times when the tool is switched off or when it is running but not actually doing the job. This may significantly reduce the exposure level over the total working period.

Identify additional safety measures to protect the operator from the effects of vibration such as: maintain the tool and the accessories, keep the hands warm, organisation of work patterns.

**Technical Data**

Impact Wrench		GDS 24 Professional	GDS 30 Professional
Article number		0 601 434 1..	0 601 435 1..
Rated power input	W	800	920
Output power	W	400	500
No-load speed	rpm	1260	1260
Max. torque for hard/soft screwdriving application according to ISO 5393	Nm	600/300	1000/500
Right/left rotation		●	●
Max. screw dia.		M 24	M 30
Tool holder		■ 3/4"	■ 1"
Weight according to EPTA-Procedure 01/2003	kg	5.7	7.3
Protection class		□ / II	□ / II

The values given are valid for nominal voltages [U] of 230/240 V. For lower voltage and models for specific countries, these values can vary.

Please observe the article number on the type plate of your machine. The trade names of the individual machines may vary.

**Declaration of Conformity** 

We declare under our sole responsibility that the product described under "Technical Data" is in conformity with the following standards or standardization documents: EN 60745 according to the provisions of the directives 2004/108/EC, 98/37/EC (until Dec. 28, 2009), 2006/42/EC (from Dec. 29, 2009 on).

Technical file at:  
Robert Bosch GmbH, PT/ESC,  
D-70745 Leinfelden-Echterdingen

Dr. Egbert Schneider      Dr. Eckerhard Strötgen  
Senior Vice President      Head of Product  
Engineering                      Certification

*ppa. Schneider i.v. Strötgen*

30.10.2007, Robert Bosch GmbH, Power Tools Division  
D-70745 Leinfelden-Echterdingen

**Assembly****Changing the Tool**

- ▶ **Before any work on the machine itself, pull the mains plug.**
- ▶ **When working with an application tool, pay attention that the application tool is firmly seated on the tool holder.** When the application tool is not firmly connected with the tool holder, it can come loose again and not be controlled.

Slide the application tool **7** onto the square drive of the tool holder **6**.

## Operation

### Method of Operation

The tool holder **6** with the tool is driven by an electric motor via a gear and impact mechanism.

The working procedure is divided into two phases:

**Screwing in** and **tightening** (impact mechanism in action).

The impact mechanism is activated as soon as the screwed connection runs tight and thus load is put on the motor. In this instance, the impact mechanism converts the power of the motor to steady rotary impacts. When loosening screws or nuts, the process is reversed.

### Starting Operation

- ▶ **Observe correct mains voltage! The voltage of the power source must agree with the voltage specified on the nameplate of the machine. Power tools marked with 230 V can also be operated with 220 V.**

### Reversing the Rotational Direction

- ▶ **Actuate the rotational direction switch **5** only when the machine is at a standstill.**

The rotational direction switch **5** is used to reverse the rotational direction of the machine.

**Right rotation:** Press the rotational direction switch **5** downward to the stop (R).

**Left rotation:** Press the rotational direction switch **5** upward to the stop (L).

### Switching On and Off

To **start** the machine, press the On/Off switch **4** and keep it pressed.

To **switch off** the machine, release the On/Off switch **4**.

### Adjusting the Speed

The speed of the switched on power tool can be variably adjusted, depending on how far the On/Off switch **4** is pressed.

Light pressure on the On/Off switch **4** results in a low rotational speed. Further pressure on the switch results in an increase in speed.

### Working Advice

- ▶ **Operate your machine only with the auxiliary handle **2**.**
- ▶ **Apply the power tool to the screw/nut only when it is switched off.** Rotating tool inserts can slip off.

The torque depends on the impact duration. The maximum achieved torque results from the sum of all individual torques achieved through impact. The maximum torque is achieved after an impact duration of 6-10 seconds. After this duration, the tightening torque is increased only minimally. However, the transmission housing heats up noticeably.

**Note:** The consequences of excessive heating-up are high wear of all hammer mechanism components and a high requirement of lubricant.

The impact duration is to be determined for each required tightening torque. The actually achieved tightening torque is always to be checked with a torque wrench.

### Screw Applications with Hard, Spring-loaded or Soft Seat

When in a test, the achieved torques in an impact series are measured and transferred into a diagram, resulting in the curve of a torque characteristic. The height of the curve corresponds with the maximum reachable torque, and the steepness indicates the duration in which this is achieved.

A torque gradient depends on the following factors:

- Strength properties of the screws/nuts
- Type of backing (washer, disc spring, seal)
- Strength properties of the material being screwed/bolted together
- Lubrication conditions at the screw/bolt connection



The following application cases result accordingly:

- A **hard seat** is given for metal-to-metal screw applications with the use of washers. After a relatively short impact duration, the maximum torque is reached (steep characteristic curve). Unnecessary long impact duration only causes damage to the machine.
- A **spring-loaded seat** is given for metal-to-metal screw applications, however with the use of spring washers, disc springs, studs or screws/nuts with conical seat as well as when using extensions.
- A **soft seat** is given for screw applications, e. g., metal on wood or when using lead washers or fibre washers as backing.

For a spring-loaded seat as well as for a soft seat, the maximum tightening torque is lower than for a hard seat. Also, a clearly longer impact duration is required.

#### Determining the Impact Duration

The diagrams (examples) indicate that the tightening torque [Nm] depends on the impact duration [s]:

- ❶ For a hard seat
- ❷ For a soft seat.

The data are mean values and vary depending on the application. As a control measure, always check the tightening torque with a torque wrench.

Diagram for GDS 24

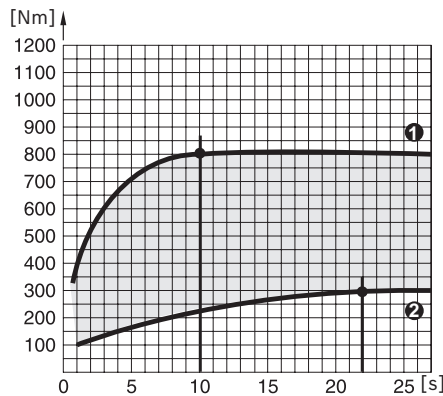

The highest torque is achieved:

- for a hard seat after approx. 10 seconds of impact
- for a soft seat after approx. 22 seconds of impact

Diagram for GDS 30

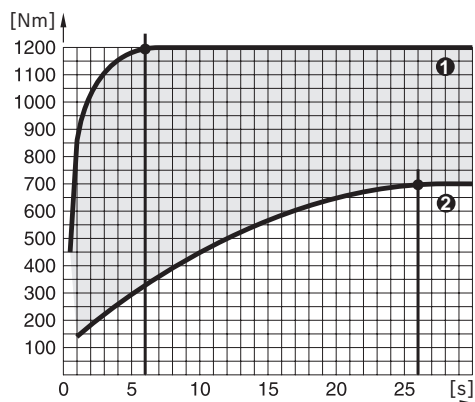

The highest torque is achieved:

- for a hard seat after approx. 6 seconds of impact
- for a soft seat after approx. 26 seconds of impact

For reference values for the maximum tightening torques of commercially available screw/bolts, see the following table.

### Reference Values for Maximum Screw/Bolt Tightening Torques

Calculated from the tensional cross-section; utilization of the yield point 90 % (with friction coefficient  $\mu_{\text{total}} = 0.12$ ). As a control measure, always check the tightening torque with a torque wrench.

Property Classes according to DIN 267	Standard Screws/Bolts								High-strength Bolts		
	3.6	4.6	5.6	4.8	6.6	5.8	6.8	6.9	8.8	10.9	12.9
M 8	6.57	8.7	11	11.6	13.1	14.6	17.5	19.7	23	33	39
M 10	13	17.5	22	23	26	29	35	39	47	65	78
M 12	22.6	30	37.6	40	45	50	60	67	80	113	135
M 14	36	48	60	65	72	79	95	107	130	180	215
M 16	55	73	92	98	110	122	147	165	196	275	330
M 18	75	101	126	135	151	168	202	227	270	380	450
M 20	107	143	178	190	214	238	286	320	385	540	635
M 22	145	190	240	255	290	320	385	430	510	715	855
<b>M 24</b>	185	245	310	325	370	410	490	455	<b>650</b>	910	1100
M 27	275	365	455	480	445	605	725	815	960	1345	1615
M 30	370	495	615	650	740	820	990	1110	1300	1830	2200

### Examples for Determining the Impact Duration (GDS 30)

Screw/bolt size M 24 of property class 8.8 =  
Screw/bolt tightening torque 650 Nm

For 650 Nm, the GDS 30 diagram reveals an impact duration of 0.8 seconds. (Diagram for GDS 30 see page 17)

#### Tips

Torque rods have shanks with precisely calibrated, reduced diameters. Thus, they act torque-limiting. A torque rod is placed between the impact wrench and the bit.

Rule of thumb for the application: Core diameter of the screw/bolt = effective diameter of the torque rod. The impact duration is to be determined through practical testing.

For hanging up, a suspension hook **1** is mounted at the machine's centre of gravity.

The position of the handle can be changed with an angle piece (accessory).

At temperatures below the freezing point, run the machine for approx. 3 minutes at no-load to improve its lubricating capacity.

## Maintenance and Service

### Maintenance and Cleaning

- ▶ **Before any work on the machine itself, pull the mains plug.**
- ▶ **For safe and proper working, always keep the machine and ventilation slots clean.**

If the machine should fail despite the care taken in manufacturing and testing procedures, repair should be carried out by an after-sales service centre for Bosch power tools.

In all correspondence and spare parts order, please always include the 10-digit article number given on the type plate of the machine.

**WARNING! Important instructions for connecting a new 3-pin plug to the 2-wire cable.**

The wires in the cable are coloured according to the following code:

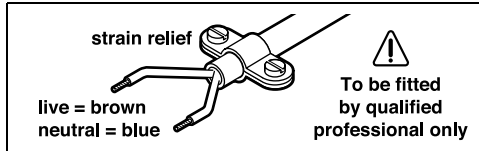

Do **not** connect the blue or brown wire to the earth terminal of the plug.

**Important:** If for any reason the moulded plug is removed from the cable of this power tool, it must be disposed of safely.

**After-sales service and customer assistance**

Our after-sales service responds to your questions concerning maintenance and repair of your product as well as spare parts. Exploded views and information on spare parts can also be found under:

**www.bosch-pt.com**

Our customer consultants answer your questions concerning best buy, application and adjustment of products and accessories.

**Great Britain**

Robert Bosch Ltd. (B.S.C.)  
P.O. Box 98  
Broadwater Park  
North Orbital Road  
Denham  
Uxbridge  
UB 9 5HJ  
Tel. Service: +44 (0844) 736 0109  
Fax: +44 (0844) 736 0146  
E-Mail: SPT-Technical.de@de.bosch.com

**Ireland**

Origo Ltd.  
Unit 23 Magna Drive  
Magna Business Park  
City West  
Dublin 24  
Tel. Service: +353 (01) 4 66 67 00  
Fax: +353 (01) 4 66 68 88

**Australia, New Zealand and Pacific Islands**

Robert Bosch Australia Pty. Ltd.  
Power Tools  
Locked Bag 66  
Clayton South VIC 3169  
Customer Contact Center  
Inside Australia:  
Phone: +61 (01300) 307 044  
Fax: + 61 (01300) 307 045  
Inside New Zealand:  
Phone: +64 (0800) 543 353  
Fax: +64 (0800) 428 570  
Outside AU and NZ:  
Phone: +61 (03) 9541 5555  
www.bosch.com.au

**Disposal**

The machine, accessories and packaging should be sorted for environmental-friendly recycling.

**Only for EC countries:**

Do not dispose of power tools into household waste!

According to the European Guideline 2002/96/EC for Waste Electrical and Electronic Equipment and its implementation into national right,

power tools that are no longer usable must be collected separately and disposed of in an environmentally correct manner.

**Subject to change without notice.**